

Series1 Nozzle Cylinders

- ML305877**
- ML306930**
- ML305665**
- ML307217**
- ML308364**

MAJOR BENEFITS

- Mounts into the same space and bolt patterns.
- Provides significantly longer life and reduces maintenance and downtime.
- Simplified design and maintenance
- Internal shock pads are standard, eliminating metal-to-metal contact.
- Cylinders are easily field repairable, maximizing your investment.
- Provides energy savings with enhanced sealing technology.
- Consult PHD for other standard and custom options available.

CSD Components

- ML305665 & ML307217** (require plumbing modifications)
- ML308364**



Series1 SB02, SB04, SB06
HR Components



ML305877



ML306930

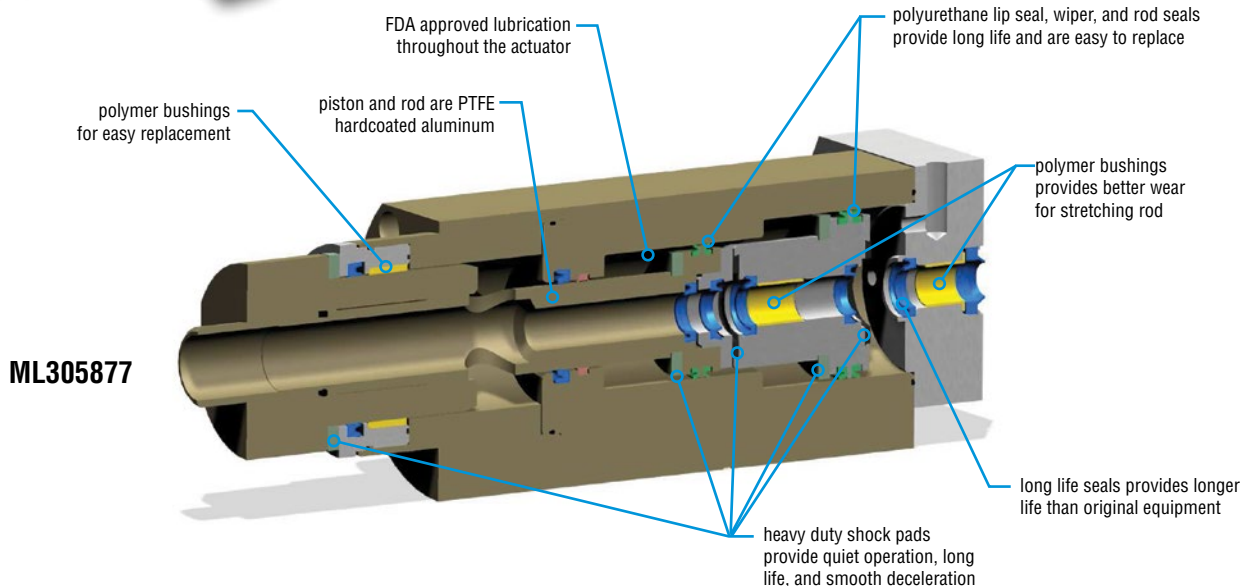

ML305877

DIMENSIONS: SERIES1 PNEUMATIC NOZZLE CYLINDER

ML307217 CSD (Requires plumbing modification)

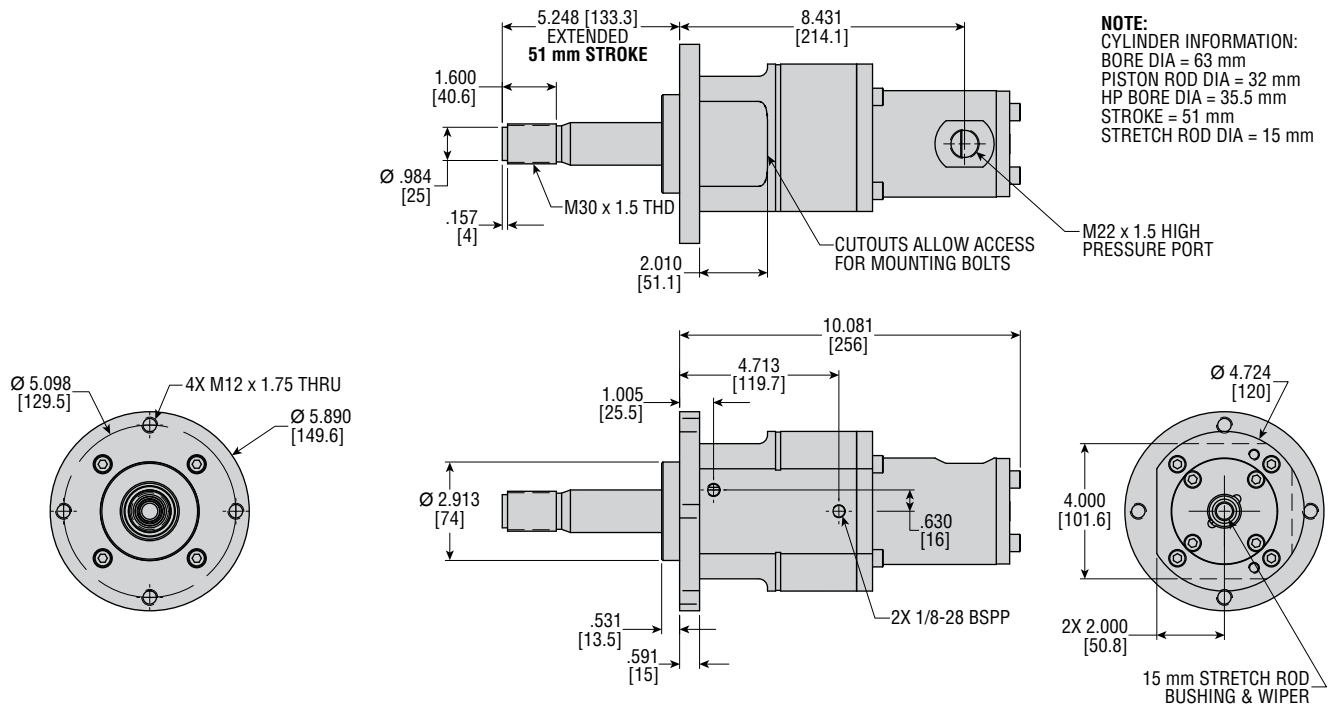

ML308364 CSD

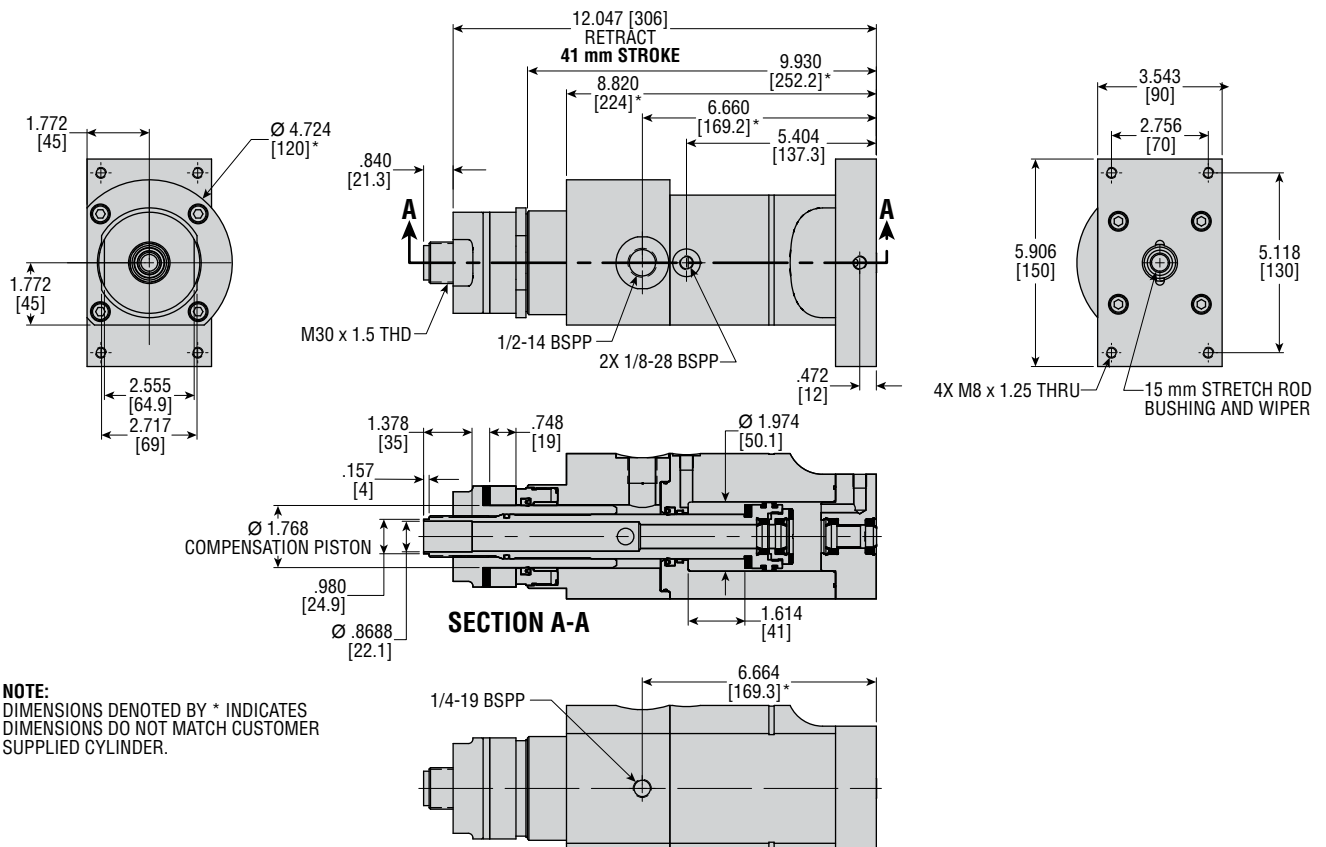

All dimensions are reference only unless specifically toleranced.

DIMENSIONS: SERIES1 PNEUMATIC NOZZLE CYLINDER

ML305665 CSD (Requires plumbing modification)

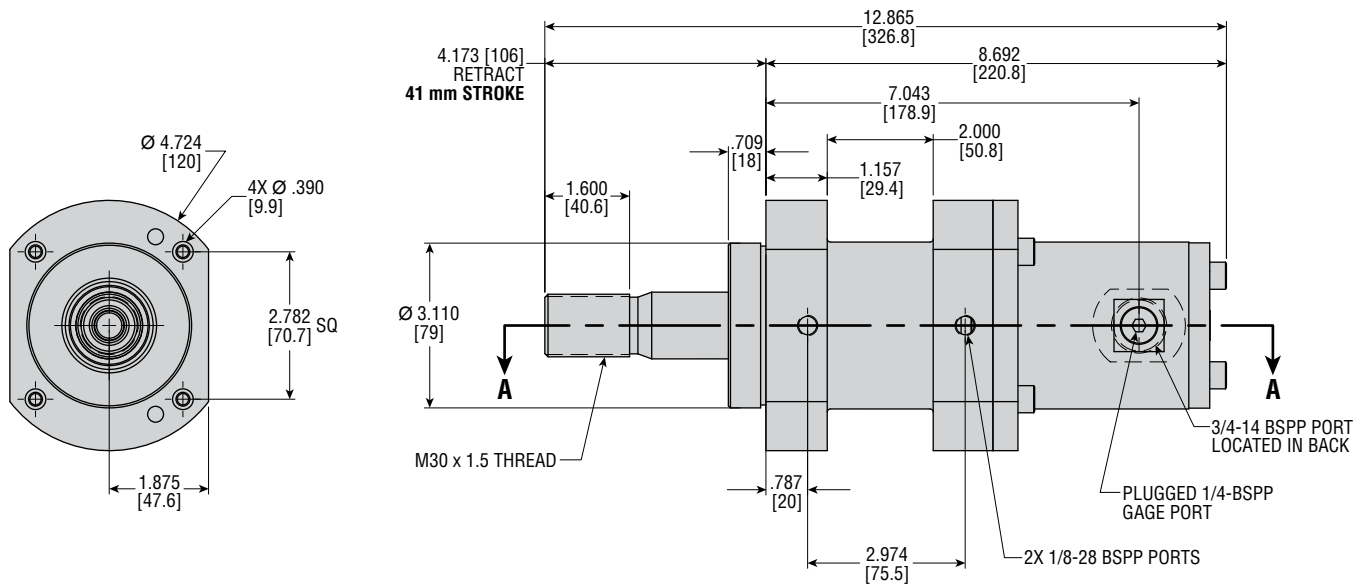

All dimensions are reference only unless specifically tolerated.